

Growatt Weather Station

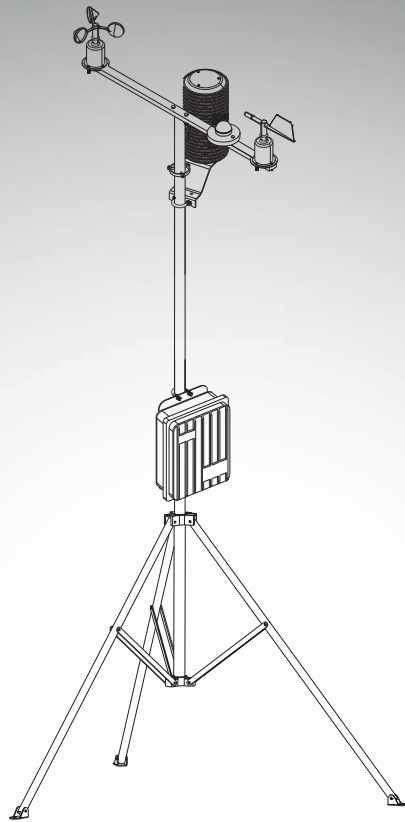

Growatt Weather Station is a compact professional 5 in 1 solution for the monitoring of weather information of solar power plant.

Mounted on a 2.5m tripod are 5 different sensors:

- Pyranometer
- Wind direction sensor
- Wind speed sensor
- Environment temperature sensor
- PV module temperature sensor

Also a data logger box is installed to collect data from sensors and communicate with remote monitoring center.

GROWATT NEW ENERGY TECHNOLOGY Co.,LTD

A: No.28 Guanghui Road, Longteng Community, Shiyan, Baoan District, Shenzhen, P.R.China.
T: + 86 755 2747 1900 F: + 86 755 2749 1460 E: info@ginverter.com

Tripod



Description

The 2.5m tripod is made of stainless steel, it is used for the mounting of various weather sensors and data acquisition box.

Technique Parameter

Height	2.5m
Material	Stainless steel
Surface treatment	polished
Main pole diameter	32mm
Weight	5kg

Wind Speed Sensor



Description

Wind speed sensor (transmitters) adopts traditional three-cup structure. The cups are made from carbon fiber material, with high intensity and good start ability; the signal processing units built in the cups can output the corresponding monitoring signal.

Technique Parameter

Measurement range	0~70m/s
Accuracy	$\pm(0.3+0.03V)$ m/s (V means wind speed value)
Resolution	0.1m/s
Starting wind speed	≤ 0.3 m/s
Operating voltage	5V
Output signal	Pulse signal
Operating environment	Temperature-40°C~50°C Humidity $\leq 100\%$ RH
Environment compatibility	IP 45
Weight	≤ 0.5 kg

Wind Direction sensor



Description

With the precise potentiometer, light metal and low inertia wind vane for wind direction detection, the wind direction sensor has very good dynamic characteristics. The product has a large measurement range, good linearity, strong ability to resist lightning.

Technique Parameter

Measurement range	0~360°
Accuracy	±3°
Resolution	1°
Starting wind speed	≤0.5m/s
Operating voltage	5V
Output signal	Voltage : 0~5V;
Operating environment	Temperature-40°C~50°C Humidity≤100%RH
Environment compatibility	IP 45
Weight	≤0.5kg

Environment Temperature Sensor



Description

Environment temperature sensor (transmitter) uses thermostat of high accuracy as inductive components which is accurate and stable and is widely used in meteorology, marine, environment, airport, harbor, laboratory, industry and agriculture area.

Technique Parameter

Measurement range	-50~+100°C
Accuracy	±0.5°C
Resolution	0.1°C
Operating voltage	2.5V
Output signal	Voltage : 0~5V;
Operating environment	Temperature-50°C~80°C Humidity≤100%RH
Weight	0.125kg

PV module temperature sensor

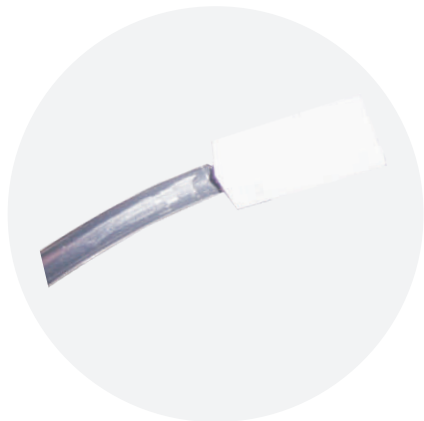

Description

PV module temperature sensor (transmitter) use high accuracy thermistor as the sensing component which has good stability.

Technique Parameter

Measurement range	-50~+100°C
Accuracy	±0.5°C
Resolution	0.1°C
Operating voltage	2.5V
Output signal	Voltage : 0~2.5V;
Operating environment	Temperature-50°C~80°C Humidity≤100%RH
Weight	0.125kg

Pyranometer

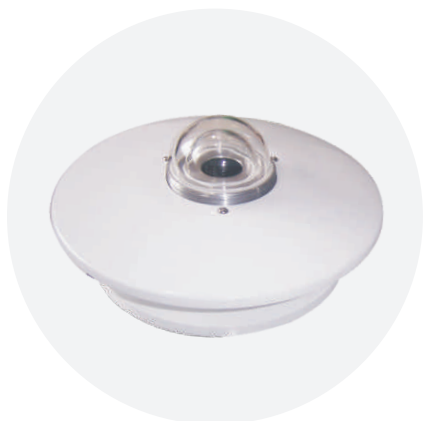

Description

Pyranometer uses high accuracy sensitometric component which is stable and reliable, with a quartz cover to prevent the affection from environment.

Technique Parameter

Spectrum range	300~3000nm
Measurement range	0~2000W/m ²
Accuracy	≤5%
Resolution	1W /m ²
Operating voltage	DC5V
Output signal	voltage: 0~2.5VDC
Sensitivity	7~14μV/W•m ²
Operating environment	-50°C~+50°C 0%~100%RH
Weight	0.42kg