

ES-108 MONO 430 BIFACIAL TOPCon 430Wp/32.38Vmp



High conversion efficiency
High module efficiency to guarantee power output



Self-cleaning glass
Coating glass for self-cleaning, reduce surface dust



Outstanding low irradiation performance
Excellent module efficiency even in the weak light conditions, such as morning or cloudy



Excellent loading capability
2400Pa wind loads, 5400Pa snow loads



0 to +5W positive tolerance.
Detailed information in Electrical Specifications



48-hour response service



IEC 61215 Ed.2
IEC 61730
UL 1703



performance warranty



warranty on materials and workmanship

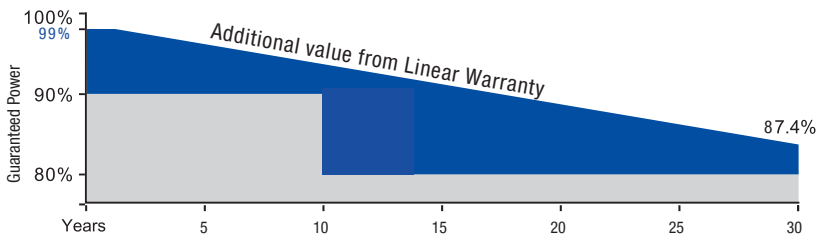

■ Linear performance warranty
■ Standard tiered warranty

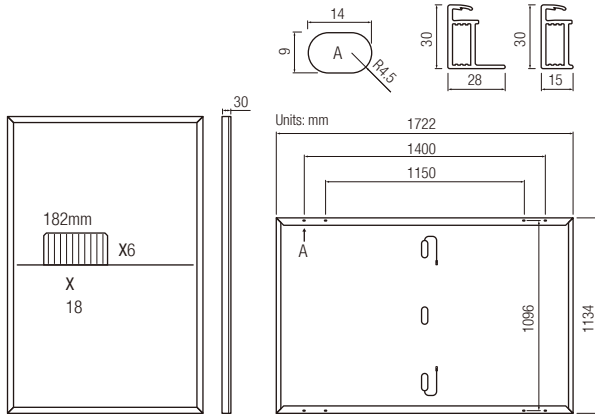

Mechanical Parameters

Cell Type	Mono TopCon
No of cells	108 (6*18)
Junction box	IP68, 3 diodes
Cable	4mm ² ; 300mm (+) / 400mm (-) or customized
Glass	Dual glass, 2.0mm/2.0mm
Frame	Anodized aluminum alloy frame
Weight	23.7kg±3%
Dimensions	1722mm x 1134mm x 30mm
Packaging	36 pcs/pallet, 936 pcs/40HQ container

Electrical Parameters

ES-108 MONO BIFACIAL TOPCon	410		415		420		425		430	
	STC	NOCT	STC	NOCT	STC	NOCT	STC	NOCT	STC	NOCT
Rated maximum power Pmax (W)	410	308	415	312	420	316	425	320	430	324
Open circuit voltage Voc (V)	37.69	35.82	37.88	36.00	38.09	36.24	38.28	36.44	38.50	36.56
Short circuit current Isc (A)	13.72	11.22	13.78	11.28	13.82	11.36	13.89	11.42	13.97	11.52
Maximum power voltage Vmp (V)	31.56	29.98	31.76	29.16	31.94	29.32	32.18	29.50	32.38	29.62
Maximum power current Imp (A)	12.99	10.63	13.07	10.70	13.15	10.78	13.21	10.85	13.28	10.94
Module efficiency (%)	21.0		21.3		21.5		22.8		22.0	

Bifacial gain 10%	410	415	420	425	430
Rated maximum power Pmax (W)	451	457	462	468	473
Open circuit voltage Voc (V)	37.69	37.88	38.09	38.28	38.50
Short circuit current Isc (A)	15.09	15.16	15.20	15.28	15.37
Maximum power voltage Vmp (V)	31.56	31.76	31.94	32.18	32.38
Maximum power current Imp (A)	14.29	14.38	14.47	14.53	14.61

Temperature Coefficient

Temperature coefficient α_{Isc}	+0.046% / °C
Temperature coefficient β_{Voc}	-0.250% / °C
Temperature coefficient γ_{Pmax}	-0.300% / °C

Operating Conditions

Operating temperature	-40°C~+70°C	Nominal operating cell temperature	45±2°C
Pmax, Voc, Isc tolerance	±3%	Front side Max. static test loading	5400 Pa
Power selection	0~+5W	Rear side Max. static test loading	2400 Pa
Maximum system voltage	1500V DC	Bifaciality	80±5%
Maximum series fuse rating	30A	Safety Class	Class II

Graphs (420W)

Current - Voltage Curve

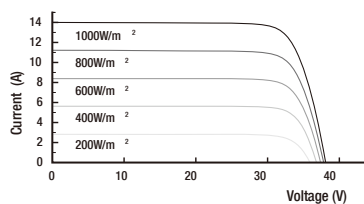

Power - Voltage Curve

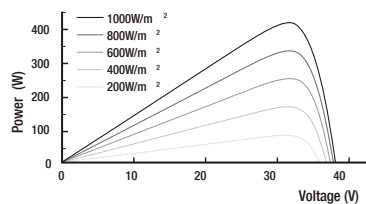

Current - Voltage Curve

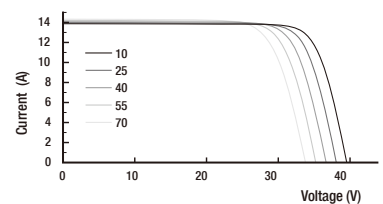

Note: the specifications are obtained under the Standard Test Conditions (STCs): 1000W/m² solar irradiance, 1.5 Air Mass, and cell temperature of 25°C. The NOCT is obtained under the Test Conditions: 800W/m², 20°C ambient temperature, 1m/s wind speed, AM 1.5 spectrum. Please contact service.support@ecosun.gr for technical support. The actual transactions will be subject to the contracts. This parameters are for reference only and are not a part of the contracts. The specifications are subject to change without prior notice.